



DLS REFERENCE SPEAKERS

OWNERS MANUAL

R6.2
2-way kit
6,5" / 16,5 cm

Welcome

Thank you for buying a DLS R6.2 speaker system. This model is a part of DLS Reference speaker line. This manual will show you how to do a correct installation. Please read the entire manual before beginning the installation. Install the speakers yourself if you feel confident with our instructions and if you have the proper tools. A poor installation job can destroy the final result even from these speakers, so if you feel unsure, turn over the installation job to someone better suited to it.

Installation

Speaker drivers:

Mount the bass speakers in the door sides of your car. We recommend you to install the drivers in a strong baffle of MDF-board or similar, this will improve the sound very much. For baffle installation see our advices on next page. An installation high up on the door side is to be preferred. If it is possible you should attach an asphalt damping mat to the door inside, this will further improve the sound.

The tweeter can be installed recessed in the door, on the dash board or in the A-pillar. It is important to fasten the speakers properly in order to avoid bad sound or rattling, a separate baffle will improve the sound also for the tweeter.

Filter boxes:

It's vital that the filter boxes are attached properly to the interior of the vehicle to avoid rattling. Don't place them close to the internal wiring of the car, this can cause interference. Avoid installing the filter boxes in the door sides because they can easily be broken because of rattling or moisture.

Wiring:

Use high quality speaker cables, avoid using the factory pre-installed cabling, they will not give the sound reproduction that you should expect from these high class speakers. Make sure the cables don't get jammed causing a short circuit to ground. This can damage the output circuits of your head unit or amplifier.

Two-way system

This 2-way system have a separate 25 mm tweeter. The filters are combined low pass and high pass in a plastic box with selectable tweeter level in four steps inside. On next pages you can see how to connect the filters and adjust the tweeter level.

The filters must be used, if you connect without them the sound becomes bad and you will destroy the tweeter. You don't have to use the passive crossover if the system is connected to separate amplifiers in an active system.

Break-in period

Allow the speakers to play at normal volume for at least 15-20 hours. After this time the performance will be correct.

Connection of speakers

Make sure you connect the cables with correct polarity to the speakers. Observe the markings on the terminals. The red marked terminal is plus and the black is minus.

Speaker phasing

To be sure to have the correct speaker polarity (phase) you can check this by using a 1,5 Volt battery. Connect a cable from the battery plus-pole to the speaker plus, and a cable from the battery minus to the speaker minus. If the speakers are correctly connected the speaker cone should move outwards on both right and left channel. This check must be made on the cables going from the speakers, to the output terminals of your car stereo or amplifier.

Warranty service

This speaker is covered by warranty, depending on the conditions in the country where it is sold. If the speaker is returned for service, please include the original dated receipt (or a copy) with the product.

Technical Assistance

For technical assistance ask the shop where the product was sold or the distributor in your country. You can also send an e-mail to info@dls.se

Information can also be found on our web-site www.dls.se We follow a policy of continuous advancement in development. For this reason all or part of specifications & designs may be changed without prior notice.



DLS Svenska AB
P.O. Box 13029
SE-40251 Göteborg, Sweden
Tel: +46 31 840060
Fax: +46 31 844021
E-mail: info@dls.se
www.dls.se

Connect to crossover box:

TWEETER LEVEL SELECTOR

Select between two different tweeter levels by moving the jumpers inside the filter box.

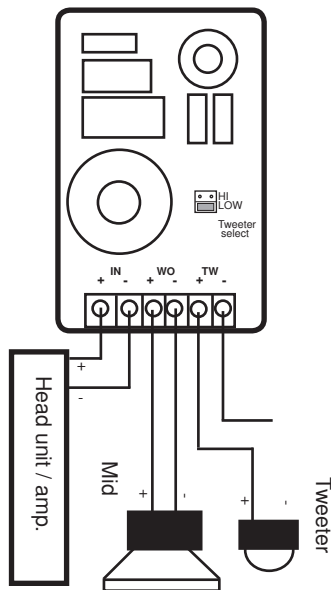

Facts DLS R6.2 bass driver

Art.no, driver	R6.2 8-20062
Size	165 mm / 6,5"
Impedance	4 ohm
Nom. RMS power	100 Watt
Max. power	200 Watt
Peak power	300 Watt
Freq. range	30Hz-6 kHz
Sensitivity	86,7 dB
Fs	48,6 Hz
Qts	0,70
Vas	15,3 litres
Cone material	Woven glass fibre
Magnet size	100 mm / 4"
Installation hole	140 mm / 5,51"
Inst. depth	78 mm / 3,07"

Facts DLS T25 tweeter

Art.no	10-21025
Size	25 mm
Impedance	4 ohm
Nom. power	50 Watt RMS
Max power	80 Watt max
Freq. range	1,5 kHz-20 kHz
Sensitivity	93 dB
Fs	1400 Hz
Overall dimensions	43 mm / 1,7"
Magnet	25 mm / 1"
Mounting depth	18 mm / 0,71"
Mounting hole	46 mm / 1,81"
Cone material	Hand treated fabric

Installation in baffles:

If you plan to use extra baffles for the installation it is very important that the baffle is stable, but it is just as important that it is shaped in a way that allows the driver to "breathe" backwards, otherwise there will be a lack in the drivers bass reproduction.

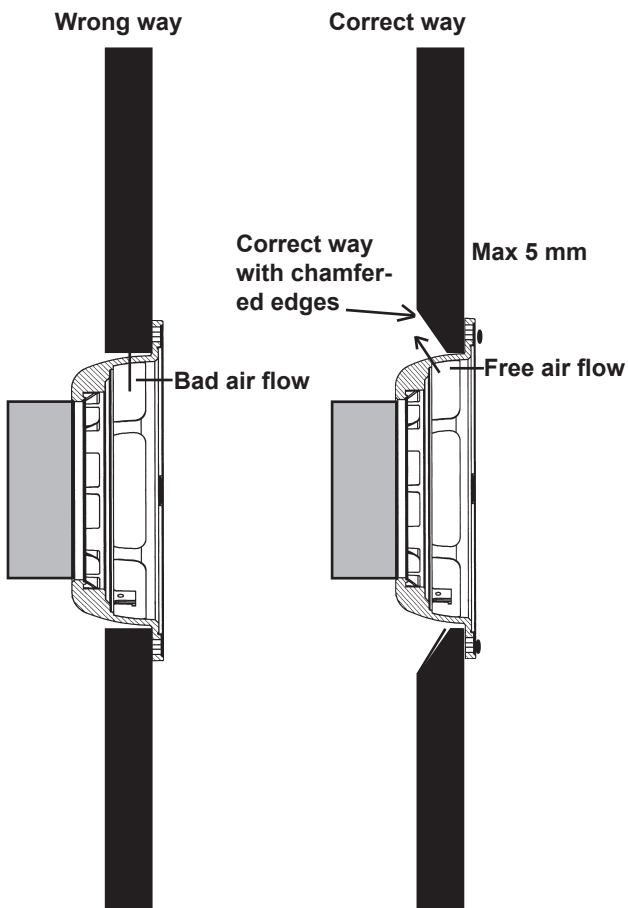

Installation of T25 tweeter:

T25 can be installed on the dashboard with the angled cup or recessed in the door side with the flush cup.

Recessed mounting:

You need a hole with a diameter of 46 mm / 1,81" in the door side. Put the two metal wings through the two tracks in the center of the cup, just as the picture shows, and attach them with the M4 screw and nut through the center hole. The cup is attached to the door side when the metal wings is pressed to the back side of the door. Put the tweeter driver into the cup with the cable going out through the bottom hole. Then attach the driver into the cup and turn it clockwise to attach to the cup. When removing the tweeter driver from the cup, turn it ccw and lift it up.



Angled surface mounting:

For angled surface mount together with the angled cup: The tweeter driver is attached to the cup by fitting the three wings on the angled cup into the tracks of the driver and then turn it clockwise. When removing the driver from the cup, turn it ccw and lift it up.

